



6'x10' Storage Shed Plan

Compare our Free vs. Premium plan

This perfectly designed plan will guide you through the entire process of building your very own shed for any backyard or garden.



Check out the benefits you would get with our **premium edition**:

| Features | Free plan | Premium edition |
|----------------------------------|-----------|-----------------|
| Steps count | 12 | 21 |
| Illustrations for Each Step | ✓ | ✓ |
| Print Ready | ✓ | ✓ |
| Step By Step Instructions | ✓ | ✓ |
| Full Materials and Cuttings List | ✗ | ✓ |
| Additional Illustrations | ✗ | ✓ |
| Additional Blueprints | ✗ | ✓ |
| Tools List | ✗ | ✓ |
| Fastening Elements List | ✗ | ✓ |
| Technical Support | ✗ | ✓ |

BUY NOW

6'x10' Storage Shed Material List

Site Preparation

- Concrete
- Bricks

Bottom Frame

- Pressure-Treated Lumber
- Plywood

Front/Back/Side Wall Frames

- Pressure-Treated Lumber

Shed's Roof

- Pressure-Treated Lumber
- Pressure-Treated Board
- Plywood
- Building paper
- Asphalt shingles
- Metal drip edge

Shed's Front Window

- Pressure-Treated Lumber
- Window beading
- Glass

Shed's Door

- Pressure-Treated Lumber
- Plywood

Front/Back/Side Wall Exterior Siding

- Pressure-Treated Lumber
- Wood siding boards

Top Frame

- Pressure-Treated Lumber

Fasteners & Hardware

- Door hinges
- Door pulls
- Surface bolt
- Corner braces
- Wood square louver gable vent
- Galvanized nails
- Wood screws

STEP 1

Foundation Preparation

1.1 Clear the area where you want to build the shed and layout for the foundation. Use the below illustration as a guide.

1.2 For the foundation, dig the trenches at least 1 foot wide and 1 foot deep.

1.3 Fill the trenches to ground level with concrete and let cure, or harden. Since curing times vary between brands, read the packaging for recommended curing times.

1.4 Once the concrete has cured, use standard-sized bricks and lay them across the foundation. You will need roughly 110 bricks for this step.

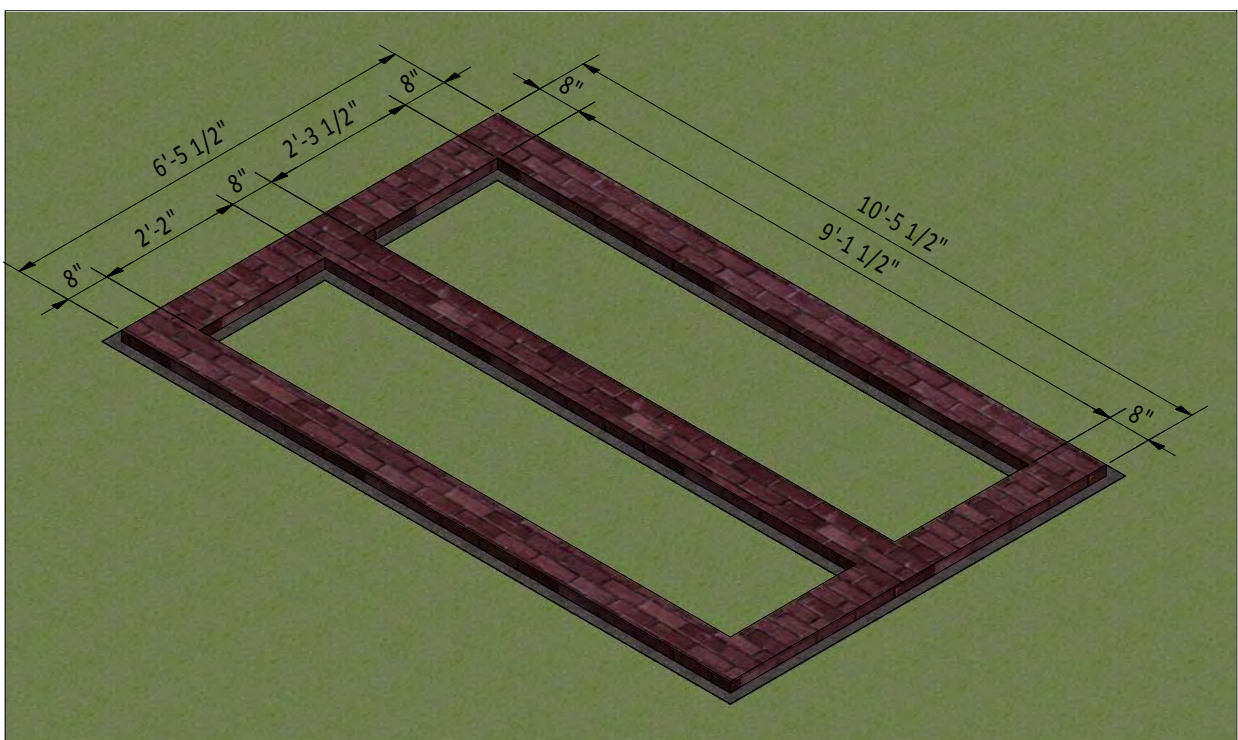
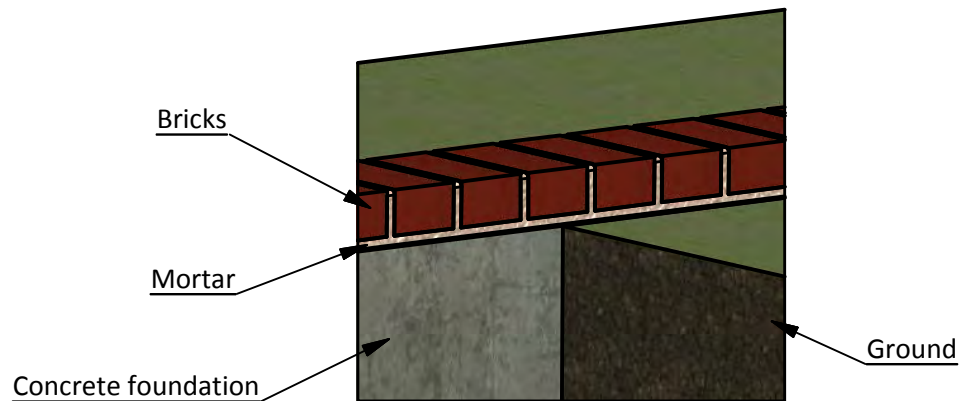

STEP 2

Framing the Floor

2.1 Assemble the frame using 1 1/2" x 7 1/4" pressure-treated lumber. You will need two boards cut to 10' that will be the rim joist and two boards cut to 5'-9" that will be the joist.

2.2 Secure the beams with 8x5" wood screws.

2.3 Using a speed square or carpenter's square, check the corners to make sure they are 90°.

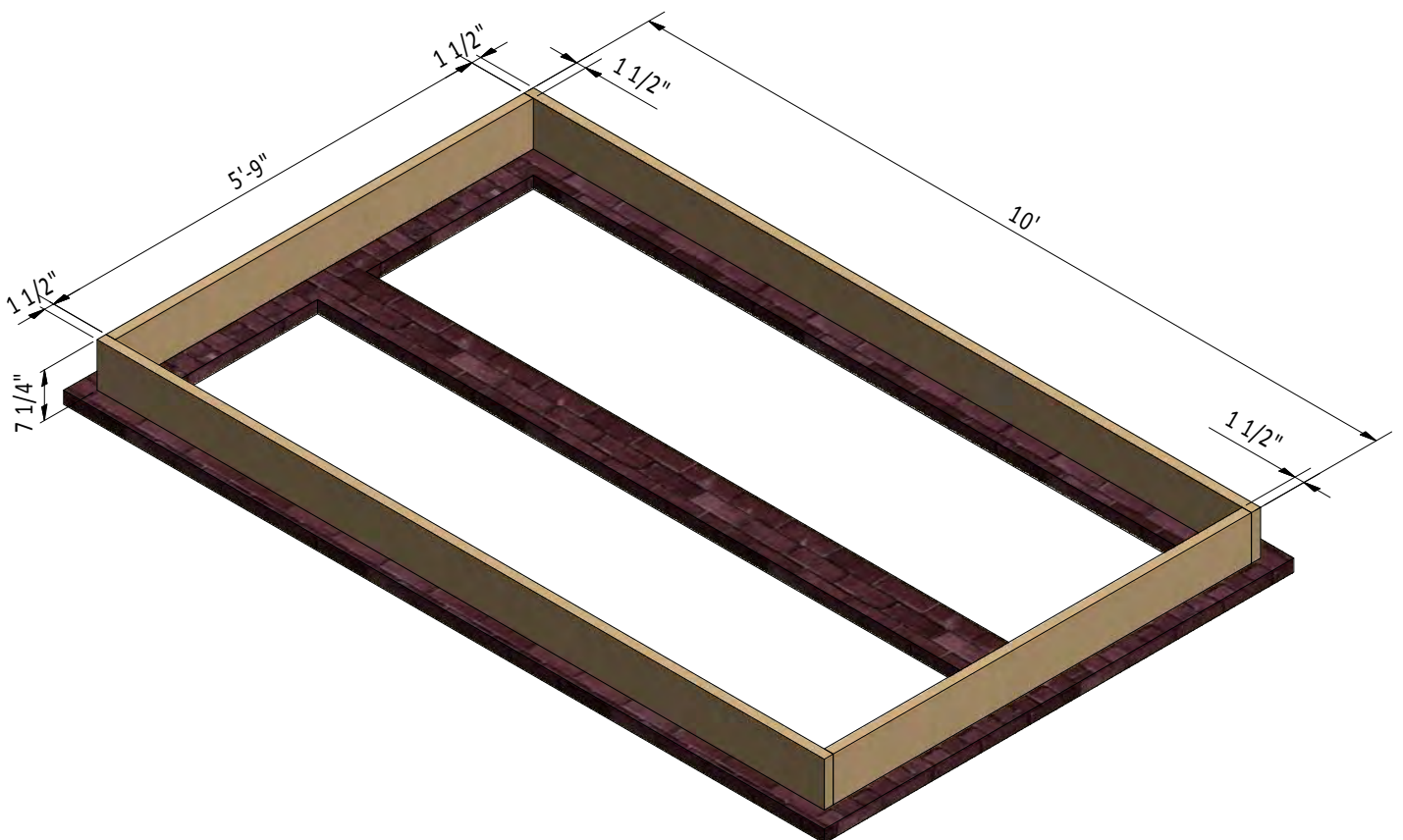

STEP 3

Install the Plywood Floor

3.1 Prepare the 9/16" plywood for the floor sheathing according to the drawing.

You will need three 3'-4" x 6' sheets.

3.2 Secure the plywood with 2" wood screws.

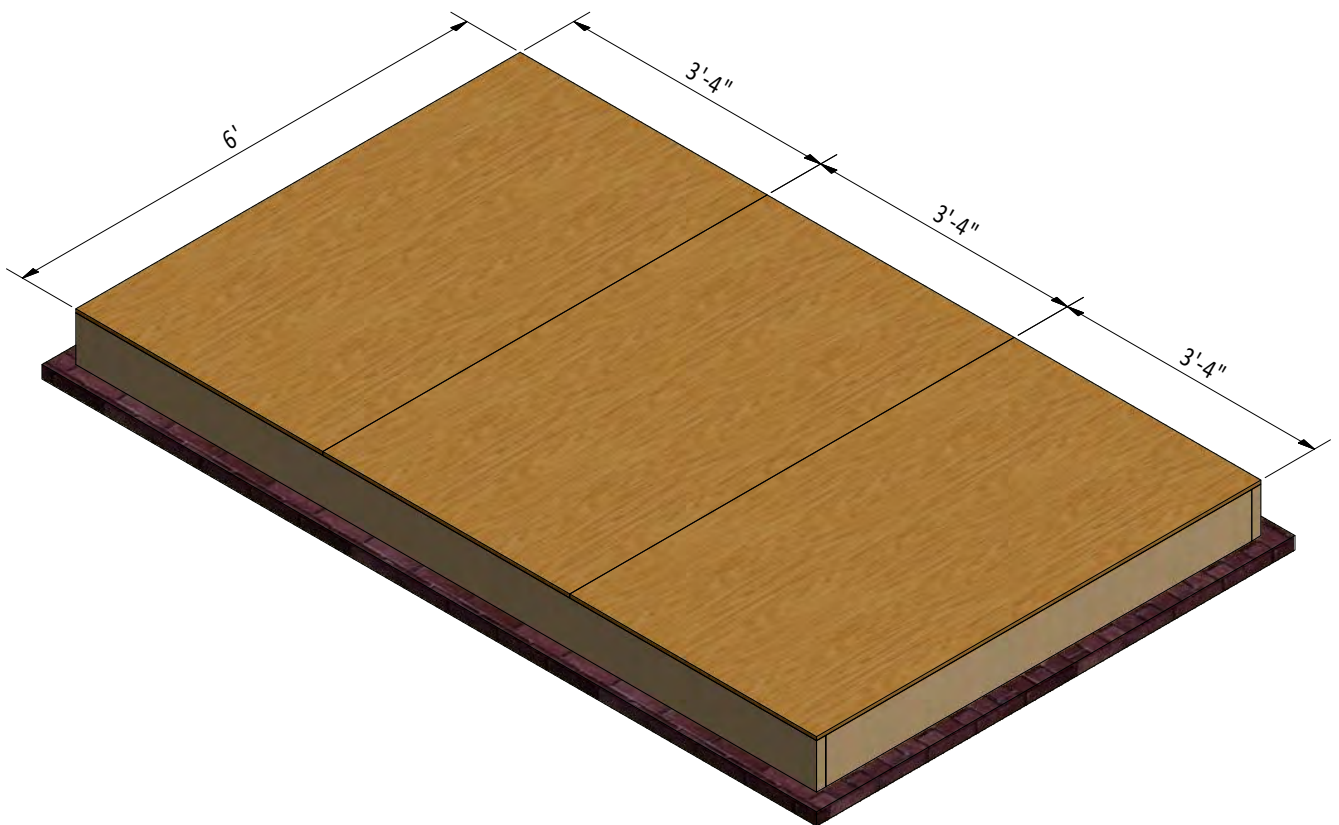

STEP 4

Assemble Front Wall Frame

4.1 Using 1 1/2" x 3 1/2" and 3 1/2" x 3 1/2" pressure-treated lumber, construct front wall frame using the drawing below as a reference. You will need six boards cut to 7'-3" and one board cut to 3'-11" that will be the studs, one board cut to 5'-5" and one board cut to 1'-11" that will be the bottom plates, one board cut to 10' that will be the top plate, one board cut to 2'-8" that will be the door header, two boards cut to 2'-2" that will be the window header and rough sill, two boards cut to 7" and one board cut to 11" that will be cripple studs.

4.2 Connect the beams with 2x3" and 2x5" wood screws.

4.3 Using a speed square or carpenter's square, check the corners to make sure they are 90°

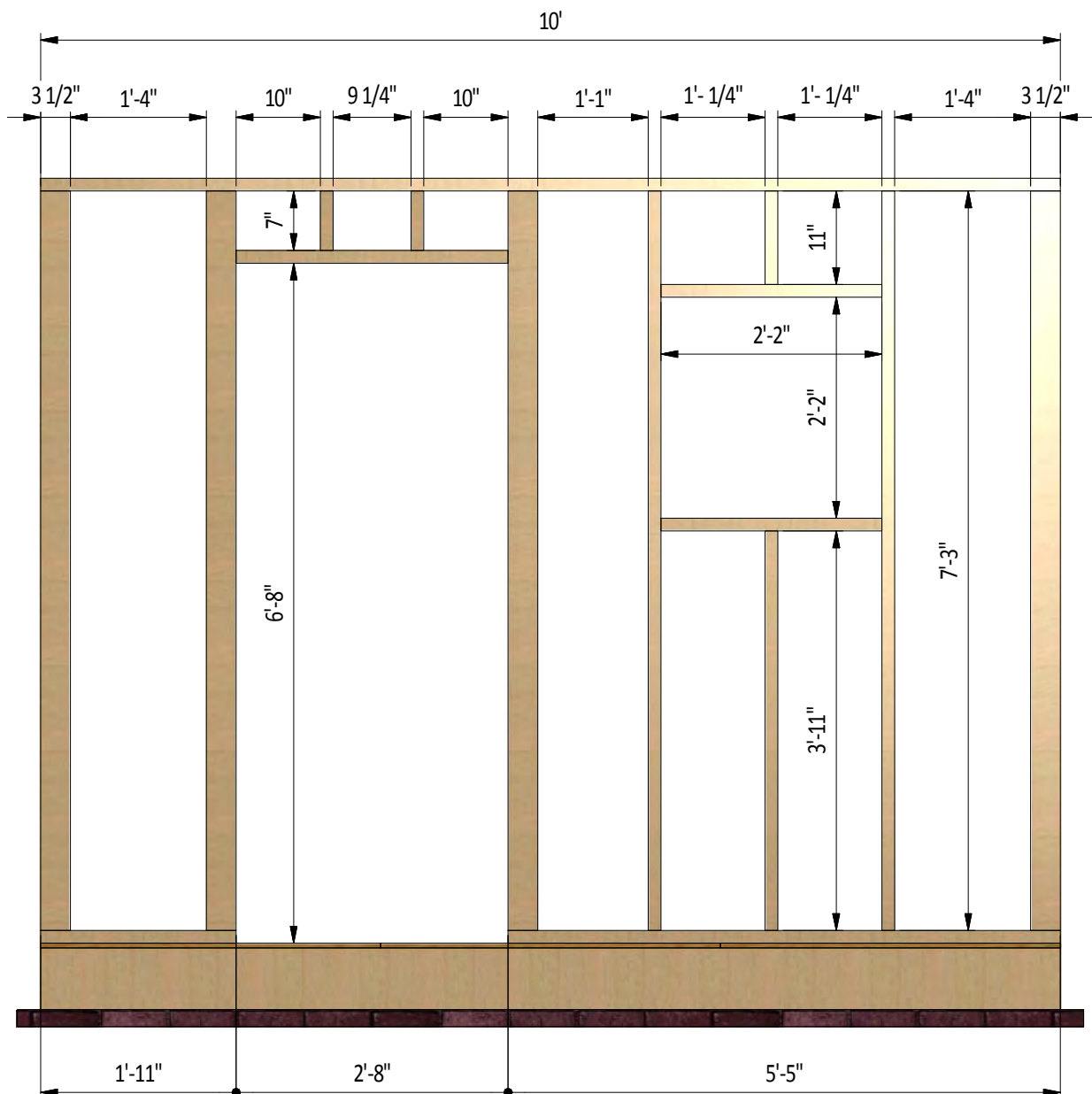

STEP 5

Assemble Back Wall Frame

5.1 Using 1 1/2" x 3 1/2" and 3 1/2" x 3 1/2" pressure-treated lumber, construct back wall frame using the drawing below as a reference. You will need nine boards cut to 8'-3" that will be the studs and two boards cut to 10' that will be the top and bottom plates.

5.2 Connect the beams with 2x3" wood screws.

5.3 Using a speed square or carpenter's square, check the corners to make sure they are 90°.

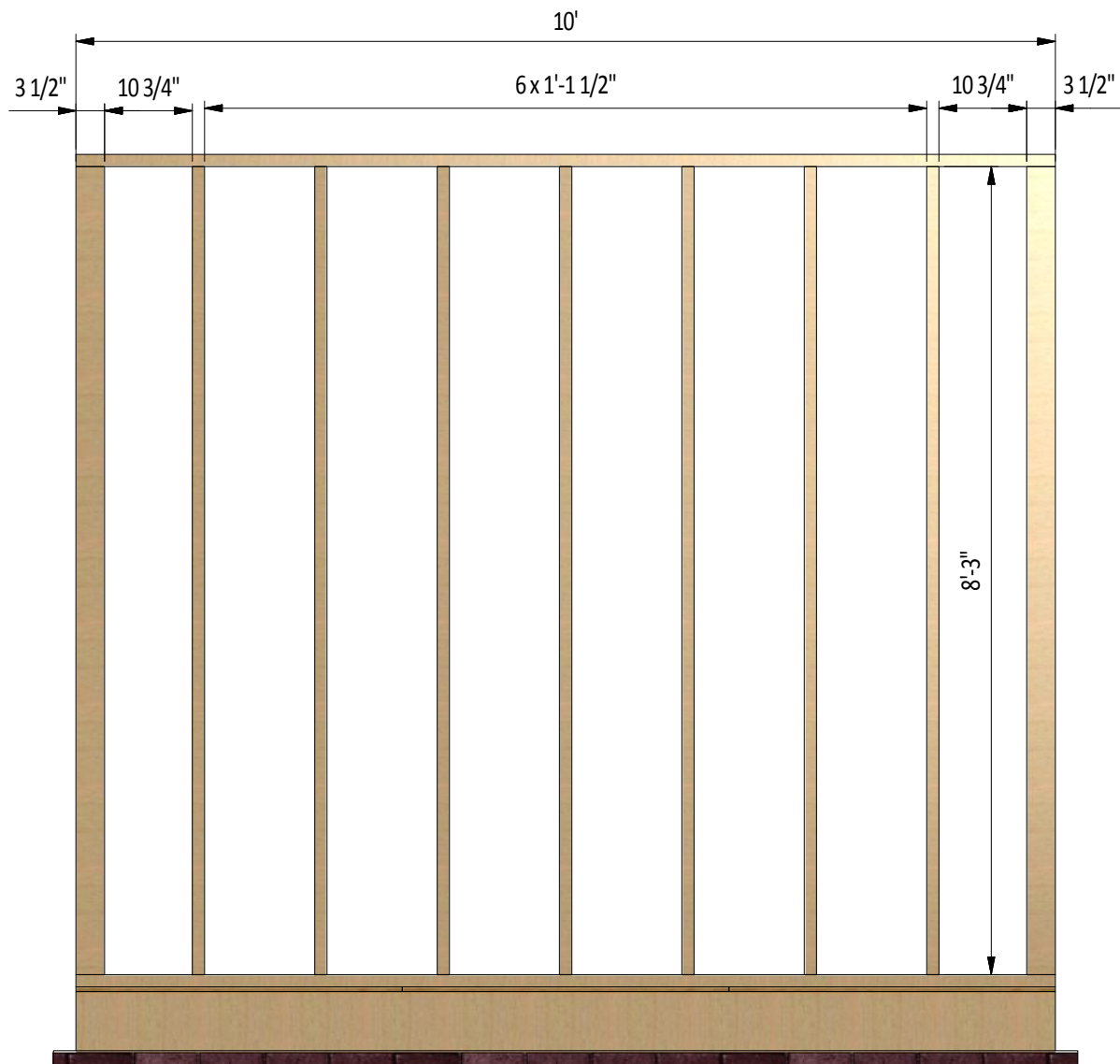

STEP 6

Assemble Right and Left Wall Frames

6.1 Using 1 1/2" x 3 1/2" pressure-treated lumber, construct side wall frame using the drawing below as a reference. You will need five boards cut to 7'-3" that will be the studs and two boards cut to 5'-5" that will be the top and bottom plates.

6.2 Connect the beams with 2x3" wood screws.

6.3 Using a speed square or carpenter's square, check the corners to make sure they are 90°.

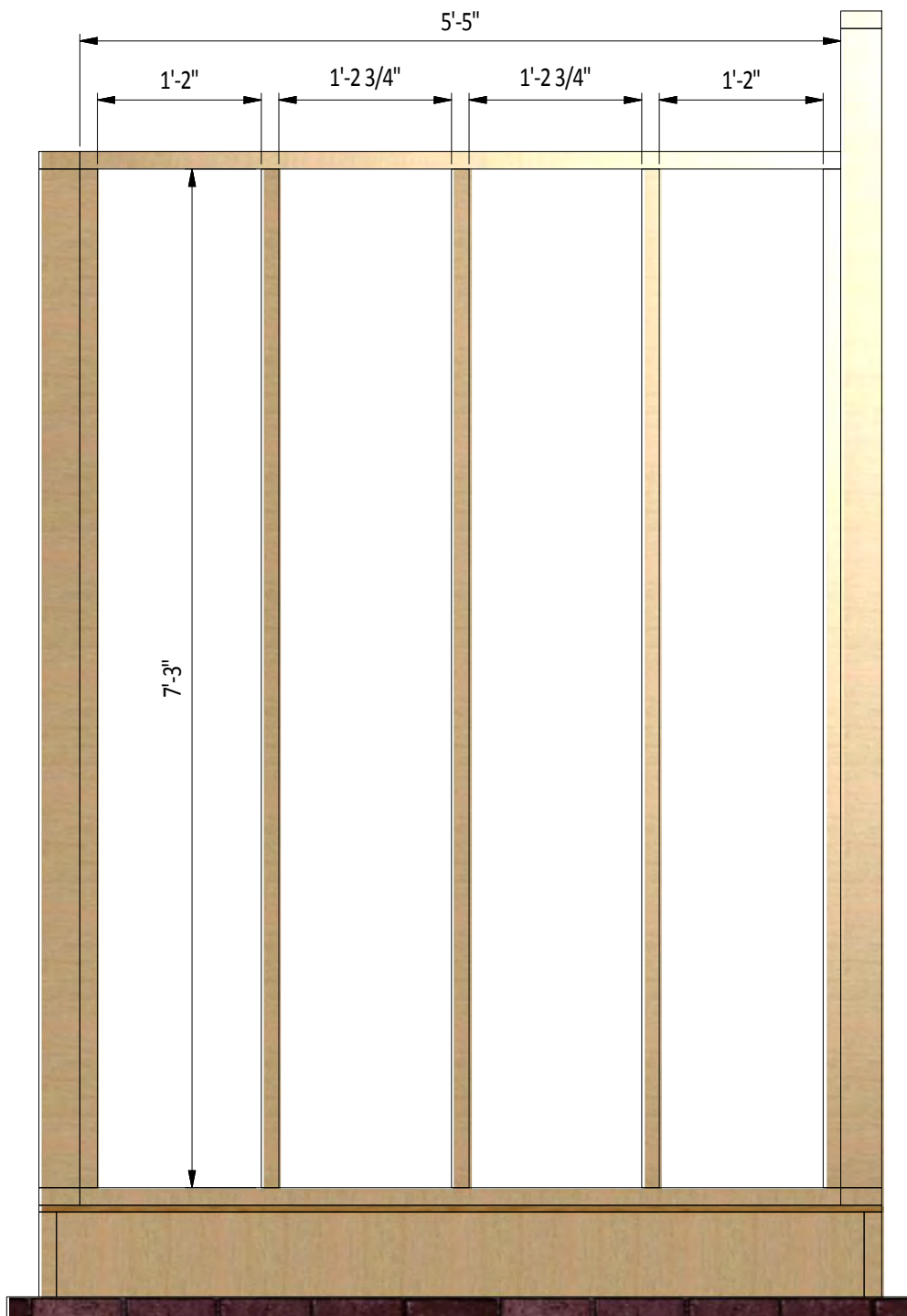

STEP 7

Assemble The Roof Frame

7.1 Using 1 1/2 " x 5 1/2 " pressure-treated lumber, cut seven rafters 7'-5" long according to the dimensions in drawing below. Cut the recesses in each beam for splicing connection with wall frames.

7.2 Connect the beams with a top frame with the help of 3" wood screws.

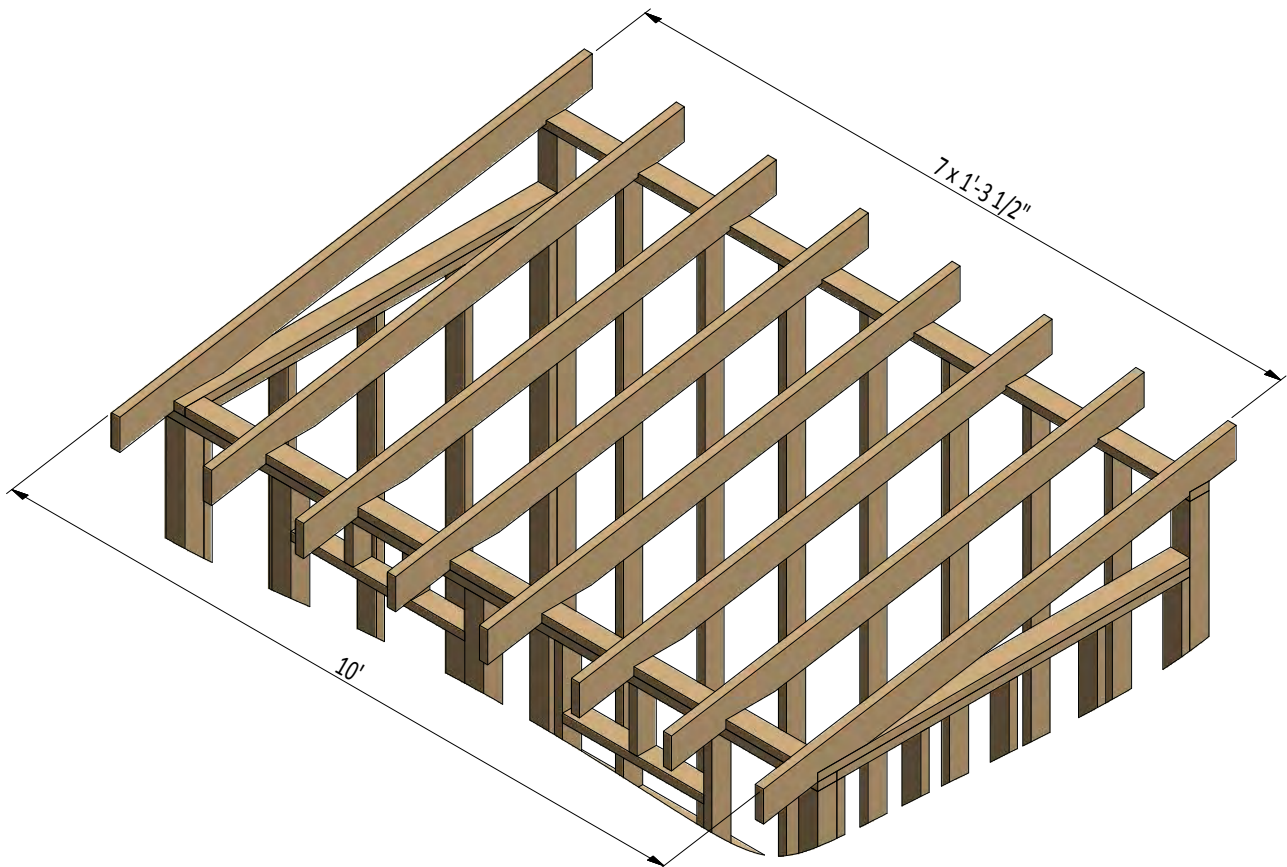

STEP 8

Install Plywood for the Roof

8.1 Cut sheets of 9/16" plywood for the roof sheathing using the drawing below as a guide.

You will need two 7'-6 1/2" x 4' sheets and one 3'-3 1/2" x 8' sheet.

8.2 Secure the plywood with 2" wood screws.



STEP 9

Window Installation for the Front Wall

9.1 Using 1 1/2 " x 2 1/2 " pressure-treated lumber, assemble the frame for the window as shown in the drawing below. You will need two boards cut to 1'-11" that will be the vertical girts and two boards cut to 2'-2" that will be the horizontal girts. Connect them with 2x3" wood screws. Mill a recess for the glass.

9.2 Prepare and install 1/8" glass into inner frame groove and fasten it by window beading from four sides. You will need one sheet 1'-11 1/2" x 1'-11 1/2" of the glass. Use 1/2" galvanized nails.

9.3 Insert window into front wall opening and connect them with 8x3" wood screws to the wall beams.

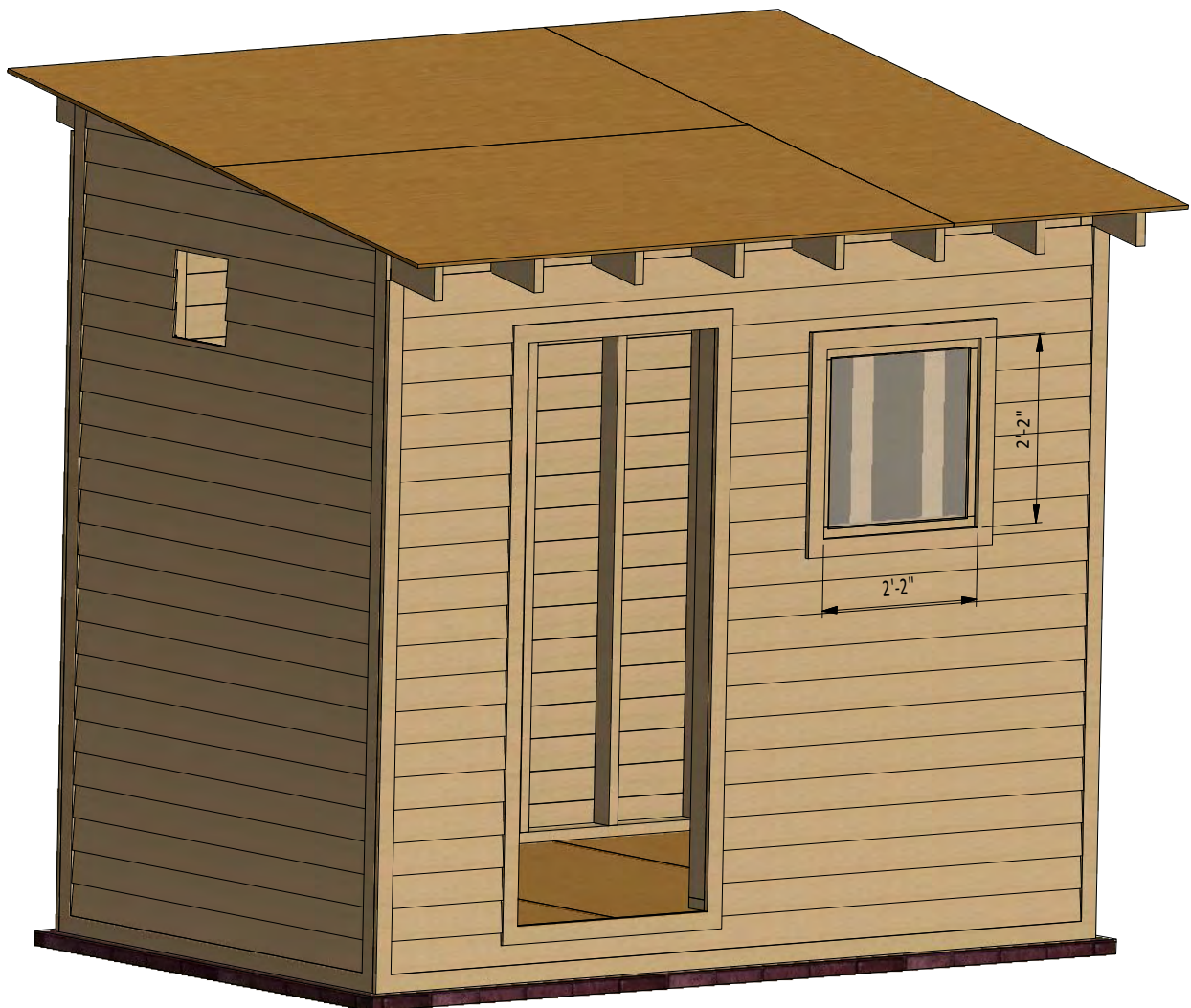

STEP 10

Assemble and Install Shed's Door

10.1 Build the door frame for the coop using 1 1/2 " x 3 1/2 " pressure-treated lumber and secure with 5" wood screws. You will need two boards cut to 6'-7 1/2" that will be the vertical girts, three boards cut to 2'-1 1/2" that will be the horizontal girts and two boards cut to 3'-6 1/4" that will be a cross braces.

10.2 Use 3/4" x 2 1/2 " pressure-treated lumber for the door trims and fasten with 2" wood screws. You will need two boards cut to 6'-2 1/2" and two boards cut to 2'-7 1/2".

10.3 Using 1/4 " x 3/4 " pressure-treated lumber, cut and install a starter course 2'-2 1/2" long.

10.4 For the exterior siding on the door, use 1/2 " x 6" wood siding boards and the illustration below as a reference.

10.5 Assemble siding shields with 2" galvanized nails.

10.6 Install three 3" door hinges using 6x1" wood screws. Finish the doors installation by attaching 4" surface bolt and 6" door pull.



STEP 11

Roof Sheathing Installation

11.1 You will need 90 Sq Ft of asphalt shingle roofing.

11.2 Add the metal drip edge to the fascias.

11.3 Cover the plywood with building paper.

11.4 Install asphalt shingle roofing using an industrial stapler.

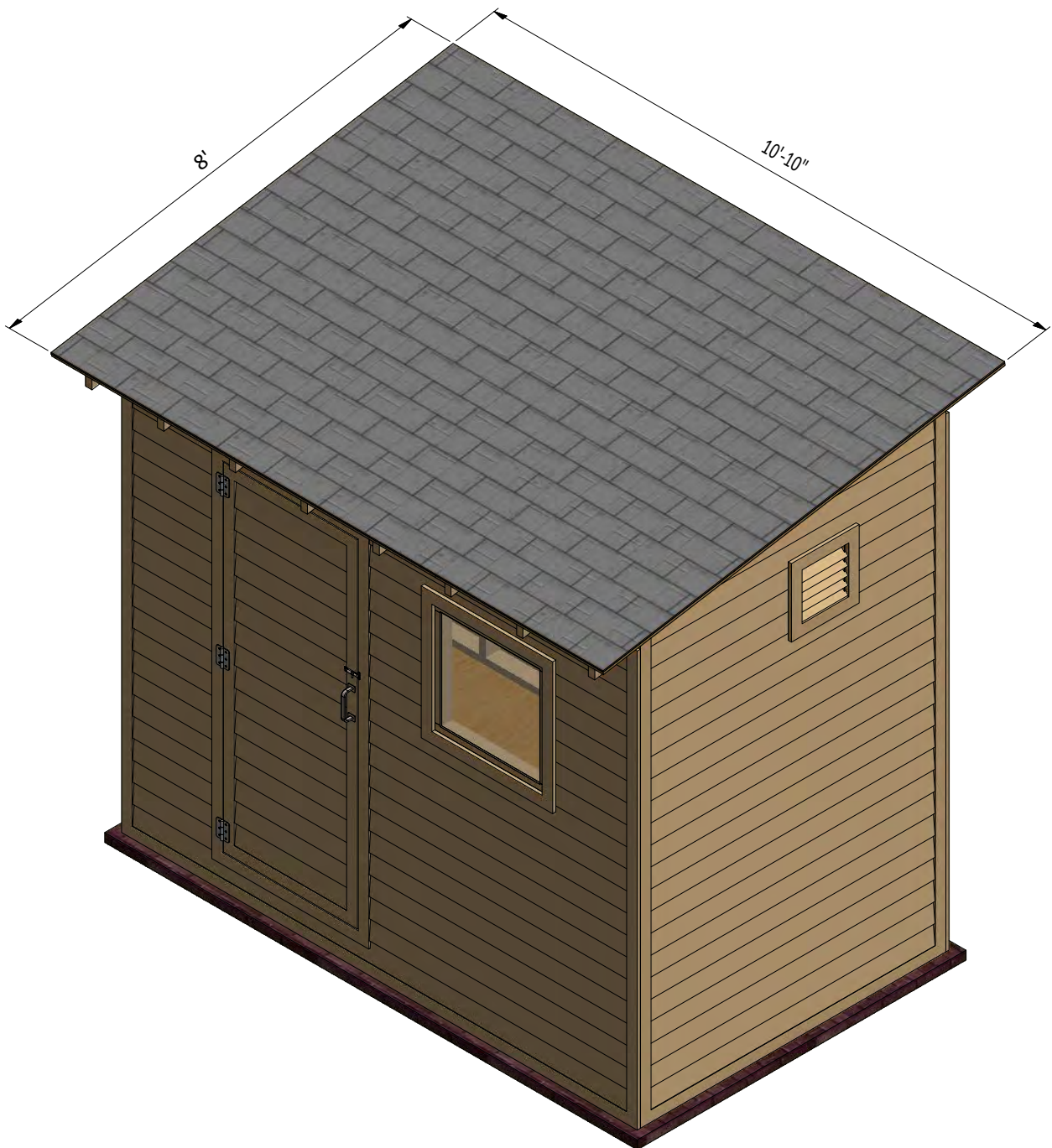

STEP 12

Shed Decoration

Now that your coop is all done, you are ready to decorate it any way you want using your favourite paint, stain, or preservative.



Compare our Free vs. Premium plan

This perfectly designed plan will guide you through the entire process of building your very own shed for any backyard or garden.



Check out the benefits you would get with our **premium edition**:

| Features | Free plan | Premium edition |
|----------------------------------|-----------|-----------------|
| Steps count | 12 | 21 |
| Illustrations for Each Step | ✓ | ✓ |
| Print Ready | ✓ | ✓ |
| Step By Step Instructions | ✓ | ✓ |
| Full Materials and Cuttings List | ✗ | ✓ |
| Additional Illustrations | ✗ | ✓ |
| Additional Blueprints | ✗ | ✓ |
| Tools List | ✗ | ✓ |
| Fastening Elements List | ✗ | ✓ |
| Technical Support | ✗ | ✓ |

BUY NOW



For more great **HOW-TO** plans please visit: <https://shedplans.org>

Copyright

The text and illustrations that appear here are the exclusive property of shedplans.org and are protected by federal copyright laws. The duplication, sale or distribution of any portion of these plans without prior written consent from the original designer will be subject to the appropriate penalties for copyright infringement. Sharing this plan on the web is only permitted with an indicated original source: <https://shedplans.org>